



6.6KW OBC-Fan

Model No.: ATC6K6-10858-A, ATC6K6-14446-A

1. Overview

1.1 Subject

ATC6K6-10858-A, ATC6K6-14446-A full-sealed on-board OBC is a product specially designed for new energy vehicle by ANNREN Technologies Co., Ltd according to China standard QC/T895-2011 Conductive On-board Charger for Electric Vehicle, which function is as the battery charger of new energy vehicle This product not only have the advantages of high efficiency, small size, high stability, long-lifetime but also have the performance of high protection level, high reliability, more protection functions, it is an ideal power supply solution for electrical vehicle. Thermal sensor is built-in the charger, has the function of over-temperature and can auto recovery when temperature decreased. With the process of full-sealing, achieve the protection level of IP67, which make sure the excellent working under the complicated operation condition.

1.2 Main Features

- 1.2.1 Support UDS diagnosis, with CAN wake-up function (advanced version only)
- 1.2.2 Full-sealed process, can reliably work in the temperature of -40°C ~60°C
- 1.2.3 Built-in thermal sensor, shut off when temperature up to 90°C
- 1.2.4 Protection level with IP67(vents for fan-cooling not included)

2. Charger Technical Specification

2.1 Environmental Specification

▲ Working environmental temperature

| Area | Lowest Temperature | Highest Temperature |
|--------|--------------------|---------------------|
| Global | -40°C | 60°C |

▲ Storage environmental temperature

| Area | Lowest Temperature | Highest Temperature |
|--------|--------------------|---------------------|
| Global | -40°C | 105°C |

▲ Humidity : relative humidity 5%~95% , no condensation

▲ Altitude : ≤3000m

▲ Working noisy : max when working ≤65dB , meet China standard QTC 895-2011

2.2 Charger regulatory requirements and reference standards

The design and manufacture of this product must meet the related requirements of vehicle which applicable regulations and standards in China, reference standards as following:



| No. | Standard Code | Standard Name | Remark |
|-----|-----------------|---|--------|
| 1 | QC/T 895-2011 | Conductive on-board charger of electrical vehicle | / |
| 2 | GB/T 30512-2014 | Prohibited substances requirement | / |
| 3 | GB/T 18387-2008 | Limits and measurement methods for electromagnetic field emission intensity of electric vehicles, broadband, 9kHz~30MHz | / |
| 4 | GB/T 18384-2015 | Safety requirements of electrical vehicle | / |
| 5 | GB/T 18487-2015 | Electric vehicle conductive charging system | / |
| 6 | GB/T 28382-2012 | Technical specifications for all-electric passenger vehicles | / |
| 7 | GB/T 14023-2011 | Limits and methods of measurement for radio disturbance characteristics of vehicles, ships and installations driven by internal combustion engines | / |
| 8 | GB/T 18655-2018 | EMC technical requirements for electronic components and subsystems of passenger vehicles | / |
| 9 | GB/T 18655-2010 | Limits and measurement methods for the radio disturbance characteristics of vehicles, ships and internal combustion engines used to protect vehicle-mounted receivers | / |

3. Charger Safety Regulations Specification

| Item | Condition | Requirement |
|--------------------------------|----------------|---------------------------------|
| Grounding resistance test | @25A/AC | $\leq 100\text{m}\Omega$ |
| Input insulation test | @1000V/DC | $\geq 20\text{M}\Omega$ |
| Output insulation test | @1000V/DC | $\geq 20\text{M}\Omega$ |
| Input withstand test | @2000V/AC 1min | Leak current $\leq 15\text{ma}$ |
| Output withstand test | @2000V/AC 1min | Leak current $\leq 10\text{ma}$ |
| Input to Output withstand test | @2000V/AC 1min | Leak current $\leq 10\text{ma}$ |



4. Charger Electrical Performance

4.1 Input

| | | |
|-------|----------------------------|-------------------|
| Input | Input voltage range | AC 85~265V |
| | Frequency | 47~63Hz |
| | Input Current | ≤32A |
| | Power Factor | ≥0.98 @ ≥3300W |
| | Efficiency | ≥93% full loading |
| | Stand-by power consumption | ≤5W |
| | Starting inrush current | ≤48A |

4.2 Output

| | | | |
|--------|----------------------------|--|-----------|
| Output | Nominal Voltage Platform | 108V | 144V |
| | Output voltage range | 70V-177V | 100V-202V |
| | Max output current | 58A | 46A |
| | Output power | 6600W@220VAC; 3300W@110VAC | |
| | Output way | CV/CC | |
| | Efficiency | ≥94% | |
| | CV accuracy | ±1% | |
| | CC accuracy | ±2% | |
| | Ripple voltage coefficient | ±5% | |
| | Output voltage rising time | <5S, overshoot<10% | |
| | Shut off response time | Current decreased below 10% in 300ms, and decreased to 0A in 500ms | |

4.3 Low Voltage Output

| | | |
|--------------------|----------------------------|------|
| Low Voltage Output | Output way | CV |
| | Output voltage | 12V |
| | Nominal current | 5.5A |
| | CV accuracy | ±2% |
| | Output Power | ≤66W |
| | Ripple voltage coefficient | ≤1% |



4.4 Control Interface

| | | |
|-------------------|---------------------------|------------------------------------|
| Control Interface | 12V wake-up input | ≤10mA |
| | 12V wake-up signal output | Max 0.2A |
| | 12V CV | Sleep current≤1mA, peak current≤5A |
| | CAN Communication | Yes |
| | Baud rate | Optional for 250Kbps, 500Kbps |
| | Terminal resistance | Not available |

4.5 Other

| | |
|----------------------|---|
| EMI | Meet GB/T 18487.3-2001 11.3.1 and GB/T 18655-2018 |
| EMC | Meet GB/T 18487.3-2001 11.3.2 and GB/T 18655-2018 |
| Harmonic current | Meet GB 17625.1-2003 6.7.1.1 |
| Protection level | IP67 |
| Vibration resistance | 10~25Hz swing 1.2mm, 25—500Hz 30m/S ² , 8 hours each direction |
| Noisy | ≤65dB (Class A) |
| MTBF | 150000H |

5. Charger Protection Functions

| | | |
|----------------------|------------------------------------|--|
| Protection Functions | Input over-voltage protection | AC270±5V |
| | Input low-voltage protection | AC85±5V |
| | Output over-voltage protection | Stop output when exceed the highest voltage ±5V |
| | Output low-voltage protection | Stop output when below the lowest voltage ±5V |
| | Over-temperature protection | Power start to decrease when internal temperature rise to 85°C, shut off when rise to 90°C |
| | Output short circuit protection | Stop output |
| | Output polarity reverse protection | Yes |
| | Grounding protection | ≤100mΩ |
| | CAN Communication protection | Automatically stop output when CAN communication fails |
| | Power-off protection | Yes |



6. Function Block Diagram

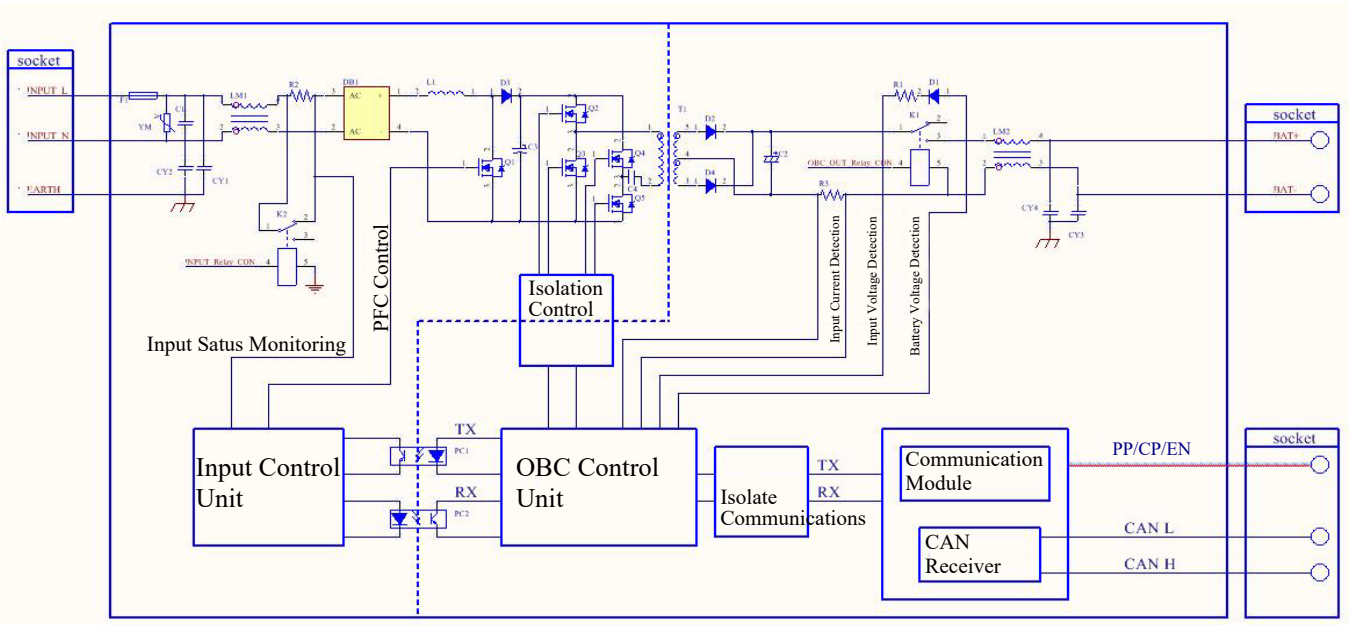

7. Control Interface

The interfaces in the charger can be grouped into two categories, one category is low voltage interface, the other is high voltage interface.

Low voltage interface includes control connector

High voltage interface includes AC220V input, DC output and HIVL

Connectors can be appointed by customer if quantity order is more than 5000pcs.

7.1 Low Voltage Connector and Pins Definition

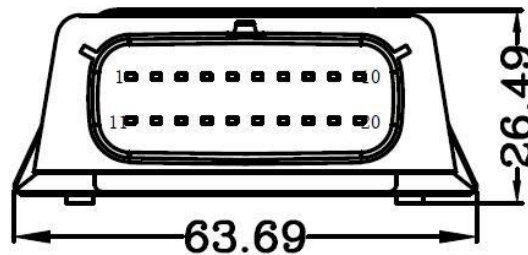



| No. | Definition | Name | Description | Remark |
|-----|------------------------------------|--|---|--------|
| 1 | Thermal resistor 1-1 | Charging socket thermal sensor 1-1 | AC charger internal temperature detection resistance signal, voltage 5V, current < 5mA. | |
| 2 | Thermal resistor 1-2 | Charging socket thermal sensor sensor 1-2 | | |
| 3 | Thermal resistor 2-1 | Charging socket thermal sensor sensor 2-1 | | |
| 4 | Thermal resistor 2-2 | Charging socket thermal sensor sensor 2-2 | | |
| 5 | Proximity detection | PP signal | The connection confirmation signal is used to test whether the charging head is connected to the vehicle. The voltage is 5V and the current is < 10ma. | |
| 6 | Charging control pilot | CP signal | It is used to test the maximum current allowed by the charging pile and test the reliability of the connection between the vehicle and the charging pile. | |
| 7 | KL30 Constant Power Input Positive | VCC + | Normal power supply input 9-16V, peak current 3A (electronic lock suction), time 1.5S, sleep current ≤1ma. | |
| 8 | Electronic lock power + | Electronic lock on the lock power positive Electronic lock unlocks power negative | Electronic lock drive, voltage 12V, peak current 2.9A. | |



| | | | | |
|----|------------------------------------|--|---|--|
| 9 | N/A | | | |
| 10 | 12V5A+ | OBC Low voltage + | Controlled output voltage 13.8V, maximum output current capacity 5.5A (long time). | |
| 11 | CAH-H | CAN High | | |
| 12 | CAN-L | CAN Low | | |
| 13 | HVIL+ | HVIL + 1 | Optional vehicle inspection vehicle or charger test to test whether the high voltage DC connector is reliably connected. The maximum voltage is 12V and the current is no more than 0.1A. | |
| 14 | HVIL- | HVIL - 2 | | |
| 15 | Electronic lock feedback wire - | Electronic lock feedback wire - | Electric lock in place signal detection, current maximum 0.5ma. | |
| 16 | Electronic lock feedback wire + | Electronic lock feedback wire + | Electric lock in place signal detection, current maximum 0.5ma. | |
| 17 | KL31 Constant Power Input Negative | VCC - | Normally input negative electrode, according to customer requirements can be connected with the OBC grounding position. Voltage 0V, peak current 5A. | |
| 18 | Electronic lock power supply - | Electronic lock on the lock power negative Electronic lock unlocks power positive | Electronic lock drive -, voltage 12V, maximum peak current 5A. | |
| 19 | N/A | | | |
| 20 | N/A | | | |



7.2 High Voltage Connectors and Pins Definition

7.2.1 AC Input

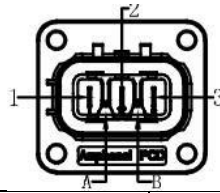

| Brand | Pin | Definition |
|------------|-----------------|------------|
| Amphenol | 1 | N |
| | 2 | PE |
| | 3 | L |
| | A, B | HVIL |
| Socket P/N | HVSL633023A | |
| Plug P/N | HVSL633063A106I | |

7.2.2 OBC Output

| Brand | Pin | Definition |
|----------|------|------------|
| Amphenol | 1 | Positive |
| | 2 | Negative |
| | A, B | HVIL |

8. Software Requirements

8.1 CAN Communication

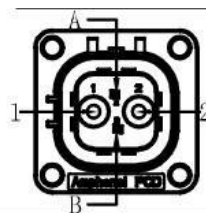

| No. | Items | Technical indicators | Notes |
|-----|--------------------------------|------------------------------------|-------|
| 1 | Baud rate | 250Kbps or 500 Kbps | / |
| 2 | CAN-BUS communication protocol | Comply with CAN 2.0B specification | / |
| 3 | Terminating resistor | No terminating resistor | / |



9. Mechanical Requirements

9.1 Size and Weight

| | Length (mm) | Width (mm) | Height (mm) | GW (KG) |
|------------|-------------|------------|-------------|---------|
| Fan-cooled | 312.8±3 | 268.36±3 | 111.2±3 | ≤7.6 |

9.2 Appearance

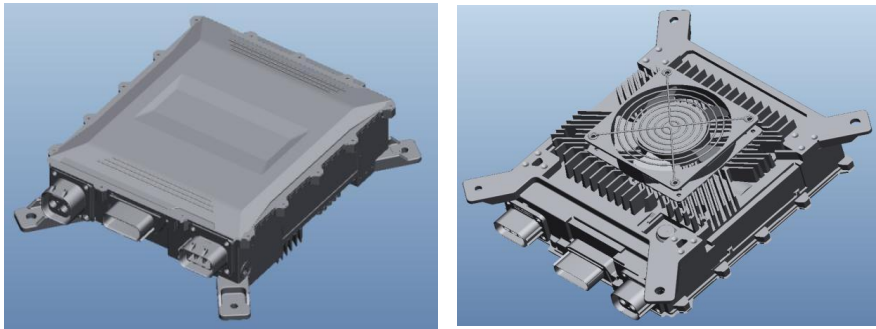

Fan-cooled

9.3 Appearance Requirements

The surface of the part should be smooth, free from defects such as delamination, rust, cracks, spots, burrs, deformation, and hand-accessible bumps. The connecting parts are complete, the parts are securely fastened, and there are no defects and damages such as rust, burrs and cracks. The connector sheath and pins should be intact and free of damage, and the components must be fastened.

10. Installation Size

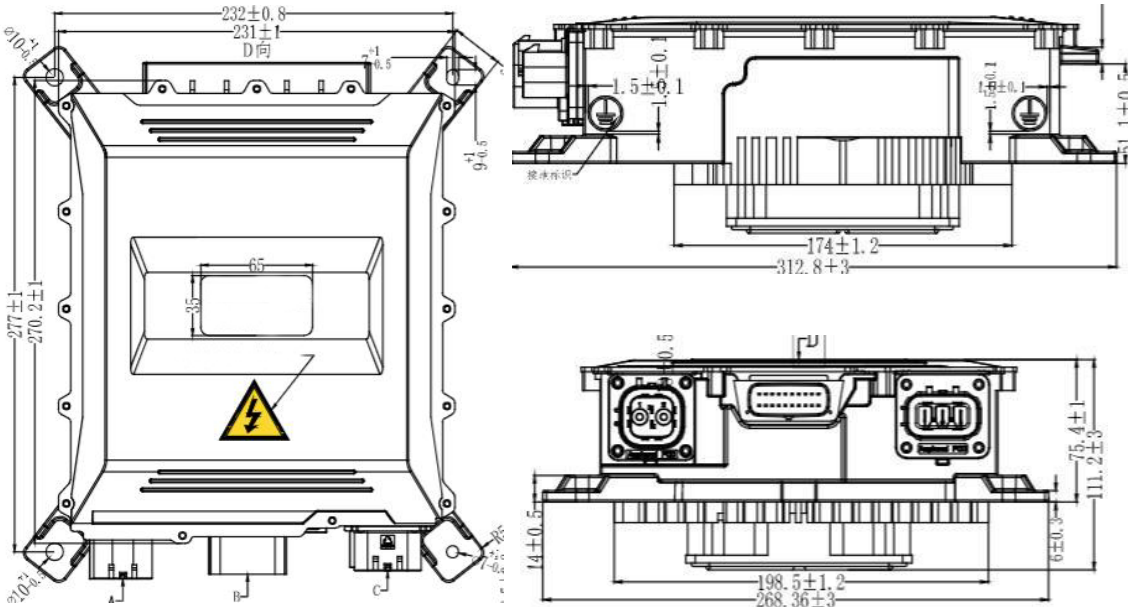



11. Installation Requirements

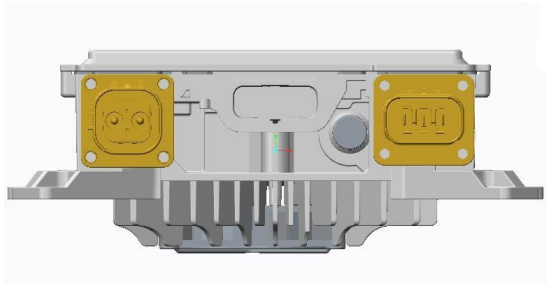

Best way to install

(At least 50mm distance off to any obstacle)

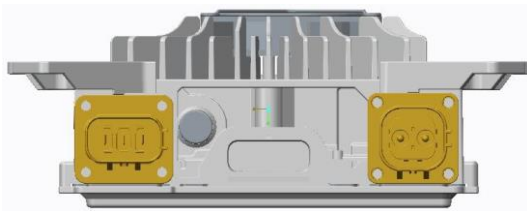

Forbidden way to install

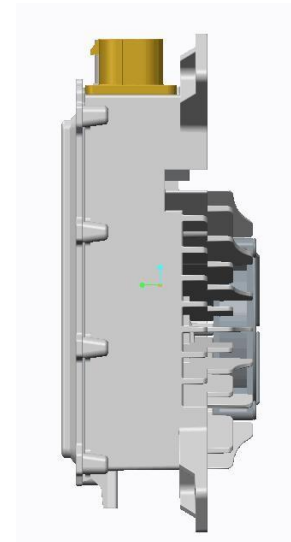

Acceptable way to install

12. Nameplate, Package, Transport and Storage

12.1 Nameplate

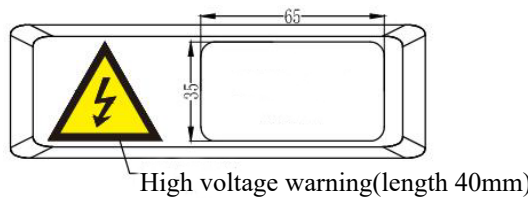

High Voltage Label for Reference

Nameplate sample is as following:

12.2 Package

The packing box shall be provided with product name, model, manufacturer identification, inspection certificate of the manufacturer's quality department, manufacturing date, etc; There is a list of accessories in the packing box:

| No. | Item | Qty | Unit | Remark |
|-----|------------------|-----|------|--------|
| 1 | On-board Charger | 1 | pc | |
| 2 | Package List | 1 | pc | |



12.3 Transportation

The product shall be transported in a firm packing box, which shall comply with the provisions of relevant national standards and shall be marked with "handle with care" and "moisture-proof". The packaging box containing the product can be transported by various means of transportation. Direct rain and snow and mechanical impact shall be avoided during transportation.

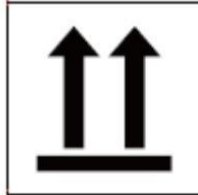

12.4 Storage

The products shall be stored in the packing box when not in use. The ambient temperature of the warehouse shall be -10-40 °C and the relative humidity shall not be greater than 80%. There shall be no harmful gas, flammable, explosive products and corrosive chemicals in the warehouse, and there shall be no strong mechanical vibration, impact and strong magnetic field. The packing box shall be at least 20cm above the ground and at least 50cm away from the wall, heat source, window or air inlet, the storage period under the specified conditions is generally 2 years, and the inspection shall be carried out again after more than 2 years.

The product shall be stored in a ventilated and dry place. At the same time, high temperature sources, fire sources and chemicals must be avoided. Store neatly to avoid throwing.

12.5 Safe Guide

Warning: remind the user that the operation is dangerous

- * It is strictly prohibited to disassemble and refit the on-board charger for repair or commissioning
- * Do not place the parts in the rain
- * Please confirm that the housing is intact before installation. If it is damaged, please replace it immediately or contact the after-sales service department
- * All plugs and sockets shall be connected firmly. If they are damaged or loose, please replace them immediately
- * It is strictly prohibited to plug and unplug the connector when the product is powered on, otherwise personal injury may be caused
- * It is strictly prohibited to open the product shell during the power on operation of the product, otherwise personal injury may be caused
- * It is strictly forbidden to touch the high-voltage live parts of the product with bare hands. Please wear insulating gloves, insulating shoes Insulating clothing, live maintenance and detection are strictly prohibited
- * During the replacement of fuses and contactors, barbaric operation is strictly prohibited to avoid damaging the product and causing potential safety hazards
- * Three core cable with grounding wire shall be selected for AC power supply, and the grounding wire
- * Please unplug the power plug if there is abnormal sound or smell during the operation of the charger
- * Please keep away from fire sources and inflammables and explosives when the battery is normally charged
- * Do not charge damaged or non rechargeable batteries

Note: remind the user that the following operations are important operations of the product

- * Do not block the air inlet and outlet of the charger to prevent overheating
- * Please make sure that the output cable is not too long to avoid the impact of line voltage drop on charging
- * Please disconnect the power cord and charging plug when moving the charger
- * The battery voltage must be consistent with the nominal voltage of the charger



- * Avoid collision, compression, pulling, twisting or shaking the charging cable
- * The product should be placed in a safe, ventilated, dust-free and rain free environment
- * Please pack and store if not used for a long time